



Features

- ★ Standard DIN size.
- ★ High-speed sampling (2000 times per second).
- ★ Original function 'SPC' (Section point compare) is useful to compare intermediate pressure on process of pressure increasing (caulking).
- ★ Built in excitation (sensor power supply) 5V, 10V selectable.
- ★ 2 setpoints comparative output.

Ordering code

ASG - 158 - -

Code	Power supply
1	90 to 110Vac
2	180 to 220Vac

Code	Output
1	None
2	BCD (Open collector)
3	BCD (TTL)
5	RS-232C
6	Analog output (4 to 20mA)
7	Analog output (0 to 10V)

Code	Comparative output
1	Relay
2	Photo coupler

Code	Built in excitation (sensor power supply)
3	5V
4	10V

Specifications

◆ General specifications

■ Measurement specifications

Operating method	Sequential comparison method
Accuracy	±(0.15% of FS +1 digit) (23±5°C)
Sampling rate	2000 times per second
Display	Main display : Red 7 segment LED (height 14.2mm) Comparative setting display : Green 7 segment LED (height 8mm)
Temperature coefficient	±(0.005% FS of reading + 0.5 digit) per °C
Polarity	'-' is displayed automatically at negative polarity
Over range display	When input exceeds the maximum display, 'o.L.' or '-o.L.'
Zero display	Leading zero suppression
Monitor display	Peak hold (PH), Digital zero (DZ), Digital zero backup (ME)
Applicable sensor	Strain gauge method each type sensor (350Ω)
Built in excitation (Sensor power supply)	5Vdc±10% 60mA or 10Vdc±10% 30mA selectable
Zero adjustment range	-3 to +2.0mV/V
Gain adjustment range	1.0 to 3.0mV/V
Minimum input sensitivity	At Built in excitation 5Vdc : 0.5μV/digit At Built in excitation 10Vdc : 1.0μV/digit
Maximum input voltage	3.0mV/V
Maximum display	9999 (4 digits)
Decimal point	Able to set to any digit (Switches by key switch)

■ External control specifications

Hold	Short COM terminal and S/H terminal at logic '0' level
Start	Open COM terminal and S/H terminal at logic '1' level
Digital zero	Short COM terminal and DZ terminal, memorize the value and display the display value
Peak hold / Peak valley hold	The type of peak hold by the each comparative 1 to 4's setup. (Switches by front key SW)
Pattern select	Able to set 4 patterns in the combination of COM terminal and P.SEL terminal 0, 1
Comparative number	Short the COM terminal and comparative terminal C1, C2, C3, C4 or '0' LEVEL.
Clear	Release the comparative result etc. at '0' level and short

■ Comparative output specifications

Control method	Microcomputer calculation method								
Setup range	Lower setup '-9999 to +9999' above including the polarity								
Comparative operation	The continuous comparison by comparative No.1 or one point comparison by comparison No.1 to 4								
Comparative condition	<table border="1"> <thead> <tr> <th>Comparative condition</th> <th>Result</th> </tr> </thead> <tbody> <tr> <td>Measurement value > Upper limit set value</td> <td>HI</td> </tr> <tr> <td>Upper limit set value ≥ Measurement value ≥ Lower limit set value</td> <td>GO</td> </tr> <tr> <td>Lower limit set value > Measurement value</td> <td>LO</td> </tr> </tbody> </table>	Comparative condition	Result	Measurement value > Upper limit set value	HI	Upper limit set value ≥ Measurement value ≥ Lower limit set value	GO	Lower limit set value > Measurement value	LO
Comparative condition	Result								
Measurement value > Upper limit set value	HI								
Upper limit set value ≥ Measurement value ≥ Lower limit set value	GO								
Lower limit set value > Measurement value	LO								
Comparative relay	Contact volume 120Vac 0.5A Resistive load Contact volume 28Vdc 1A Resistive load								
Photocoupler output (NPN type)	Voltage MAX 30V electric current MAX 20mA Less than 1.2V at setting output saturated voltage 20mA								
Hysteresis	Configurable from 1 to 999 digit in each comparative setup (only comparative No.1)								

◆ Common specifications

Memory backup	Keep the setup data for about 10 years at EEPROM
Operating temperature	-5 to 50°C
Operating relative humidity	35 to 85% (non-condensing)
Storage temperature/humidity	-10 to 70°C 60%RH or less
Power supply	100Vac ±10% or 200Vac ±10% (50/60Hz)
Power consumption	7VA max. at 100Vac
Dimensions	96mm(W) x 48mm(H) x 144mm(D) DIN size
Weight	Approx. 550g
Dielectric strength	500VAC per 1 min. : Between Input terminal - Comparative output Between Input terminal - Output COM terminal (BCD : D.COM, ANALOG OUT : -, RS-232C :SG) 1500VAC per 1 min. : Between Power supply terminal - Input terminal, case, comparative output 1500VAC per 1 min. (Power supply 100Vac specification), 2100VAC per 1 min. (Power supply 200Vac specification) : Between Power supply terminal - Output COM terminal (BCD : D.COM, ANALOG OUT : -, RS-232C :SG)
Insulation resistance	500Vdc, 100MΩ or more on the above terminals
Noise immunity	Power supply terminal normal / common mode ±1500V rising 1ns square wave noise range 500ns
Accessory	Instruction manual / terminal cover

◆ Input / output specifications

■ BCD data output specifications

TTL

Measurement data	Tristate parallel BCD positive logic latch output
Polarity signal	[1] level at negative display
Over signal	[1] level at over display
Printing command signal	Positive pulse at a certain period in each measurement completion basis (by sampling speed)
Above signal	TTL level fan out = 2 5V CMOS compatible. Negative logic available

Open collector (NPN type)

Measurement data	At the negative logic 'logic 1', transistor 'ON'
Polarity signal	At the negative display, transistor 'ON'
Over signal	At the OVER signal, transistor 'ON'
Printing command signal	After completed the measurement in a certain period, setting transistor 'ON' (by the same sampling rate.)
Transistor output volume	Voltage MAX 30V, Electric current MAX 15mA Less than 1.2V at setting output saturated voltage '15mA'
Output response	750μs

★ ENABLE input

Short between Enable terminal and D.COM terminal or setting '0' level, the data output will be high impedance.

■ RS-232C output specifications

Electric characteristic	In conformity with EIA RE-232C
Synchronization scheme	Start-stop synchronization method
Communication system	Full duplex
Transmission speed	2400 / 4800 / 9600 / 19200 bps
Start bit	1 bit
Data length	7 bit
Error detection	Even parity
Stop bit	2 bit
Delimiter	CR/LF
Character code	ASCII code
Transmission control procedure	750μs

■ Analog output specifications

Able to set any display range of analog output,

Resolution	Equivalent to 14bit
Temperature coefficient	±200ppm per °C
Output response	700μs (10% to 90%)

Analog output	Load resistance	Accuracy	Ripple
0 to 10V	10kΩ or more	±(0.5% of FS)	50mV-p
4 to 20mA	0 to 270Ω		25mV-p

Accuracy is when (23±5°C 45 to 75%RH)

4 to 20 ripple is when Load resistance 250Ω, Current 20mA

Dimensions

◆ Front view

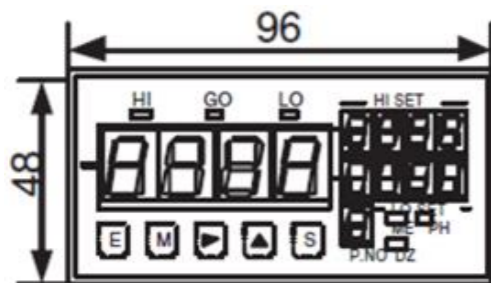

◆ Back view

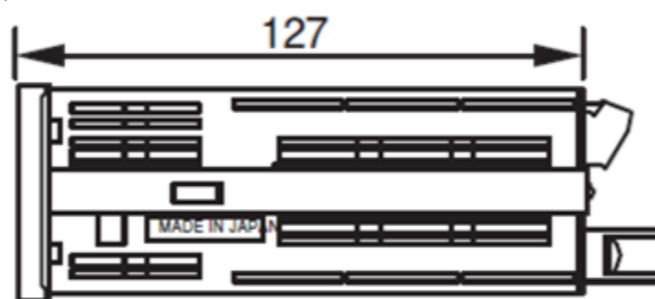

◆ Panel cutout

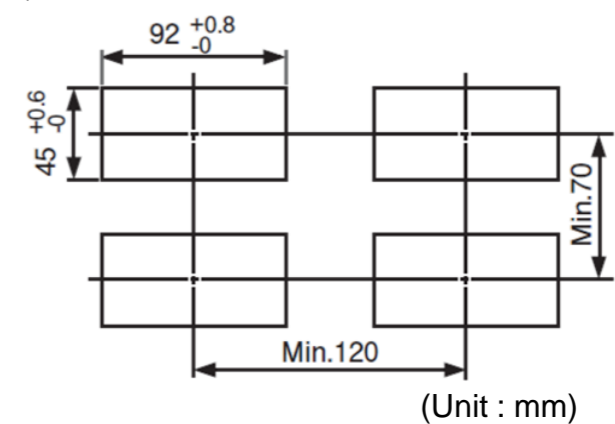

Terminal connections

◆ Upper side screw terminal

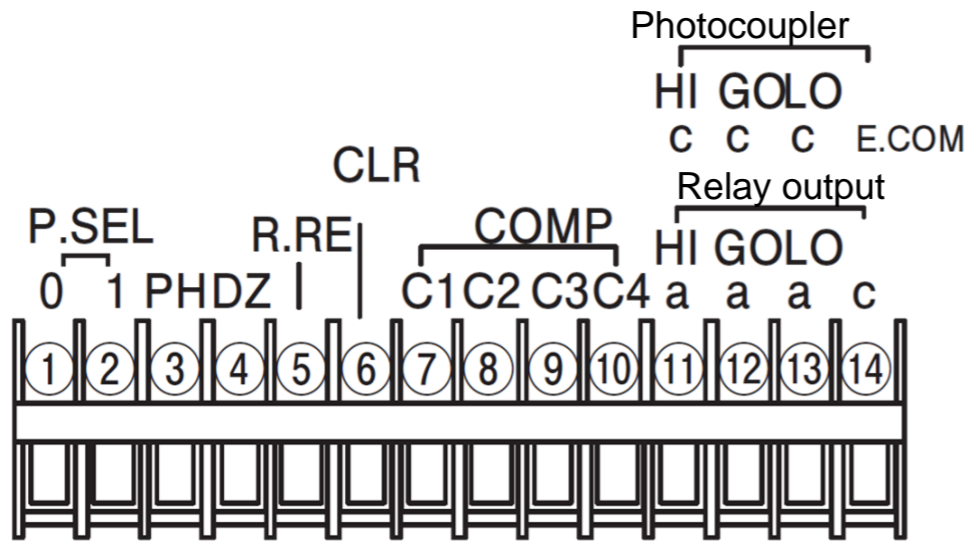

◆ Lower side screw terminal

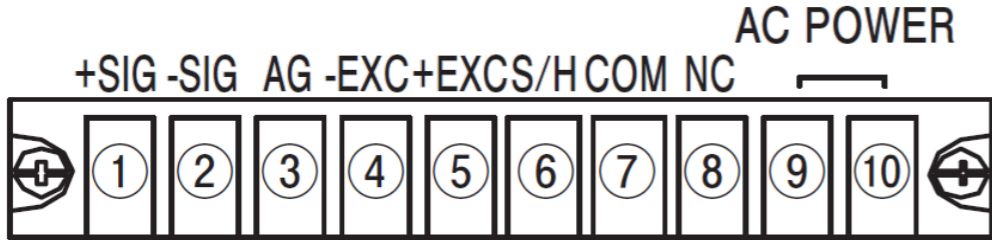

◆ BCD output

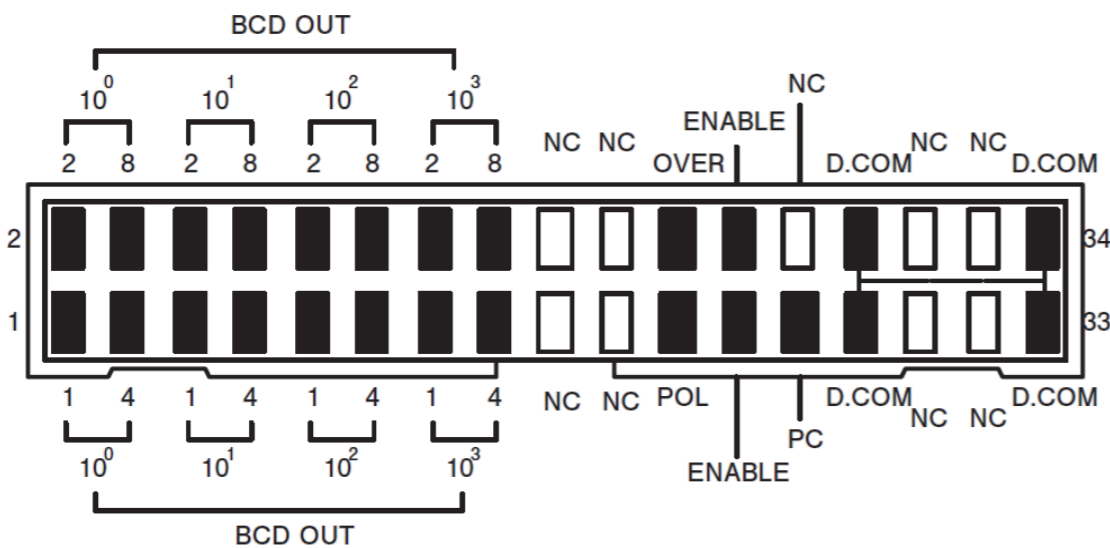

(MIL standard conformity connector)

Notes : Unable to use NC terminal as intermediate terminal.

◆ Analog output

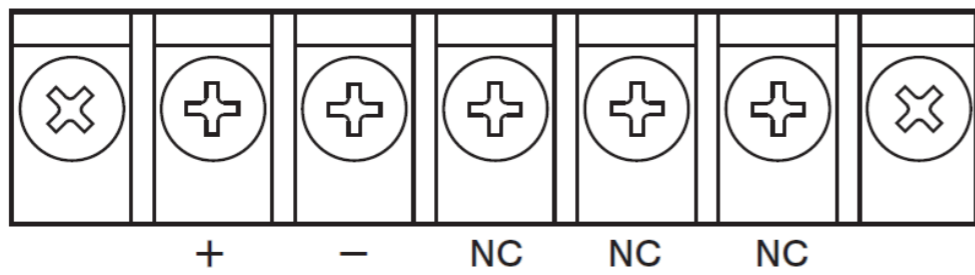

Notes : Unable to use NC terminal as intermediate terminal.
In case analog output model, either 4-20mA or 0-10V is available.

◆ RS-232C D-sub

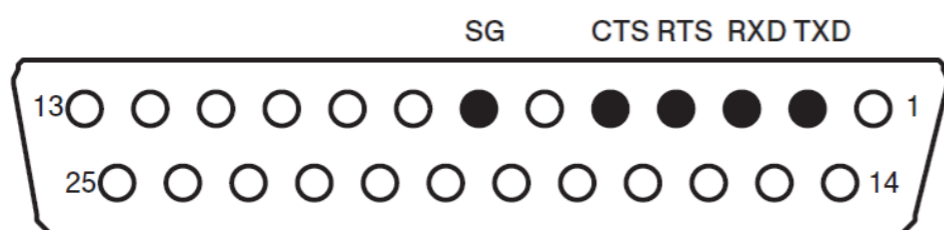

Applicable connector 17 JE-23250-02 (OSA) (DDK company made).

Notes : Unable to ○ terminal as intermediate terminal.

Distributor Sales and Technical Support
Topac Inc.,
231 CJC Highway Cohasset MA 02025 USA
Tel: 781 740 8778
Fax 781 740 8779
Email: sales@topac.com
Internet: http://www.topac.com

Request a quotation or further information